

**The Maple Pump is a horizontal piston pump for pumping solvent/waterborne paints, solvents and other suitable materials.**

The unit combines an energy efficient air motor with low shear fluid section technology from the range of Smart Electric Pumps.

The Maple Pump achieves a reciprocating drive by using high technology ground steel spool and sleeve air valves to control the air motor reversal, providing reciprocating motion.

The patented air valve design ensures a positive magnetic detent for the main and pilot air valves thus removing the possibility for a stall condition. The air motor also utilises the patented Binks Low Ice quick exhaust technology to prevent air valve freezing conditions when high cycle speeds are employed.

Equal thrust on each stroke due to the horizontal configuration incorporating the dual piston rod design gives a balanced fluid pressure output and reduces fluid pressure fluctuations to a minimum.

The air pump is furnished with twin exhaust mufflers to control exhaust noise emission. An adapter kit is available to facilitate connection to a remote exhaust system if required.

**BINKS®**

## **Maple 15/3 Air Driven Pump**

- Low Ice Air Motor using quick exhaust technology (Patented design).
  - Pneumatic spool and sleeve valves incorporating magnetic detent to eliminate stall condition (Patented feature).
- Stainless steel fluid sections – ideal for waterborne, solvent based and xirallic materials.
- Tungsten carbide ball seats and ceramic coated pistons – ensure maximum operating life between servicing.
- High quality materials and surface treatments are used in the construction of this pump to ensure both extended operational life and good future appearance.
  - Equal thrust on each stroke – gives equal flow pressure.
- No external exposed shaft packing's / seals eliminating the need for preventative maintenance.
- Sanitary inlet and outlet connections guarantee a smooth internal pipe connection without paint entrapment.

## Maple 15/3 Air Driven Pump

Specifications	
Part No.	104009
Recommended max. Continuous cycle rate	20 cycles/min (7.5lpm)
Intermittent cycle rate	40 cycles/min (15lpm)
Fluid volume/cycle	0.10 US Gal/0.375 L
Equivalent flow at 60 cycles/min	6 US Gal/22.5 L
Air volume/cycle	0.17scfm (4.8L/m) @ 45 psi (3.1 Bar)
Air volume/cycle	0.33scfm (9.3L/m) @ 90 psi (6.2 Bar)
15 cycles/min	5scfm (142L/m) @ 90 psi (6.2 Bar)
30 cycles/min	10scfm (283L/m) @ 90 psi (6.2 Bar)
Ratio	3:1
Air Inlet Pressure	15-90 psi/1-6.2 Bar
Air inlet size	3/8" BSP/NPS
Inlet/Outlet fitting	1" Sanitary
Weight	46lbs/21kg

### Accessories

192006	1" Sanitary gasket
192009	1" Sanitary clamp
192779	Exhaust tube adapter (1" NB hose)
192803	1" Manifold plug



Detail for remote exhaust connection showing plug and tube adapter fitting.

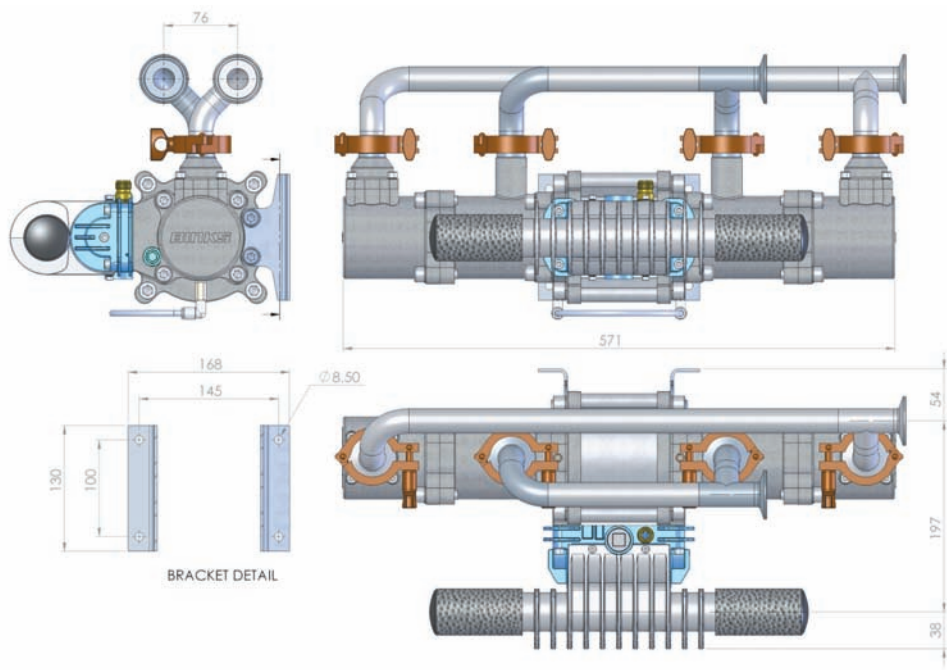

**Finishing Brands (UK) Limited**  
 Ringwood Road, Bournemouth, Dorset  
 England BH11 9LH  
 Tel: +44 (0)1202 571111  
 Fax: +44 (0)1202 573488  
 Email: marketing-uk@finishingbrands.eu

**Finishing Brands Germany GmbH**  
 Justus-von-Liebig-Strasse 31,  
 63128 Dietzenbach Germany  
 Tel: +49 (0) 6074-403-233  
 Fax: +49 (0) 6074-403-281  
 Email: marketing-de@finishingbrands.eu

**Surfaces et Finitions**  
 163-171 Avenue des Auréats, BP 1453  
 26014 Valence cedex FRANCE  
 Tel: +33(0)4 75 75 27 00  
 Fax: +33(0)4 75 75 27 59  
 Email: marketing-fr@finishingbrands.eu