



WATER PAINTING BOOTH

MODEL: *MINI SINGLE*



**ACTIVE SOLUTIONS BETWEEN
INDUSTRY AND AMBIENCE**

ARDESIA SRL via Biagio di Santolino 96, 47892 – Aquaviva, Repubblica di San Marino
Tel: +378.0549805565 Fax: +39.05411811003 info@ardesiarsrl.net www.ardesiarsrl.net
The content of this brochure is for illustration and advertising. Ardesia Srl reserves the right to make any necessary changes to improve the products.

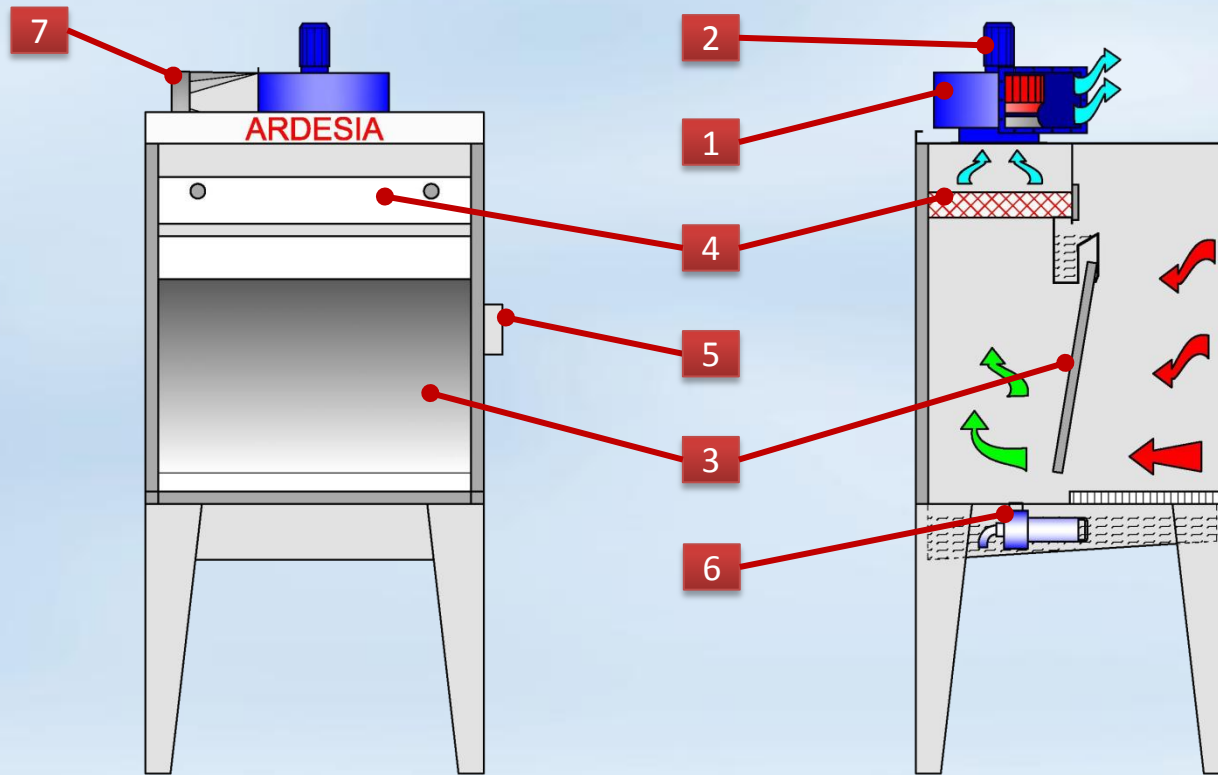

CERTIFICATION

**DESCRIPTION:**

This type of painting booth is suitable for suctioning and demolishing the pigments and fumes emitted from paint-spray made with synthetic solvents, organic and water. The removal of the pigments and fumes occurs with a frontal veil of water and with "Paint-Stop" filter. It is used mainly for the painting of small objects, for the testing of paint for laboratories. This booth is built with modular panels of galvanized press-folded sheet-iron.

EQUIPMENT:

1. Antispark centrifugal electrical fan
2. Energy-saving electric motor IE2
3. Frontal zinc plated veil
4. Metallic drawers with "Paint-Stop" filter
5. Wired electrical panel IP 55
6. Stainless steel electrical immersion pump
7. Change section

MODEL: MINI SINGLE

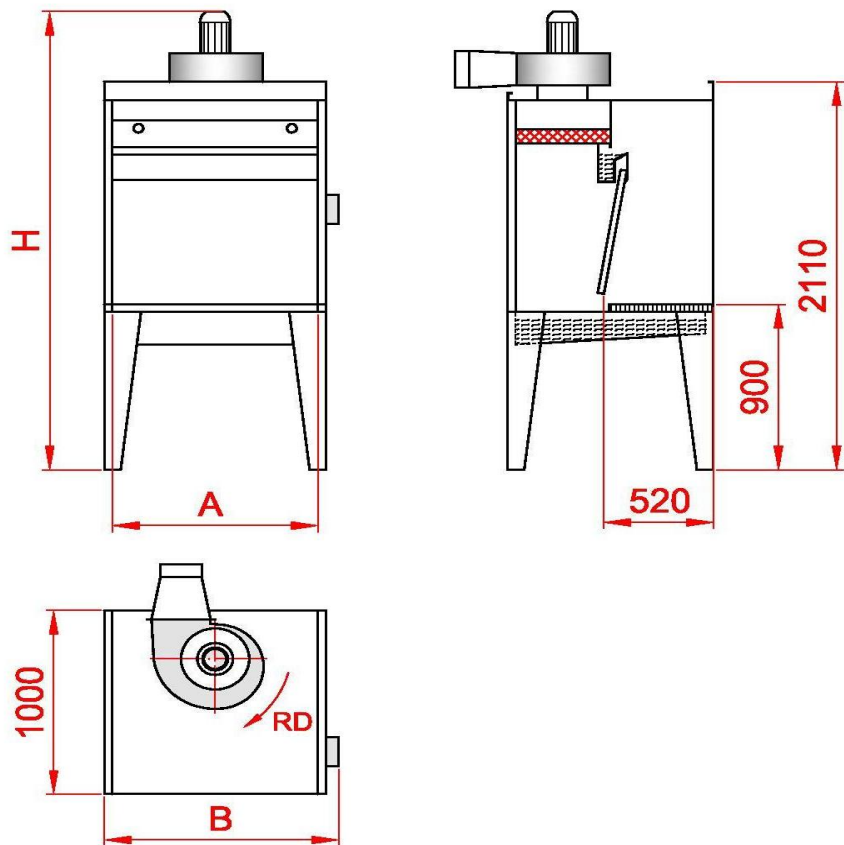

Model	A Usable width, mm	B Overall width, mm	H Overall height, mm	Diameter outbound tube, mm	Exhaust fan, power, kW	Nominal air flow m ³ / h
MINI SINGLE -1	1000	1190	2600	250	0,55	2000
MINI SINGLE -1.5	1500	1690	2650	250	0,75	3000
MINI SINGLE - 2	2000	2190	2700	300	1,1	4000

