

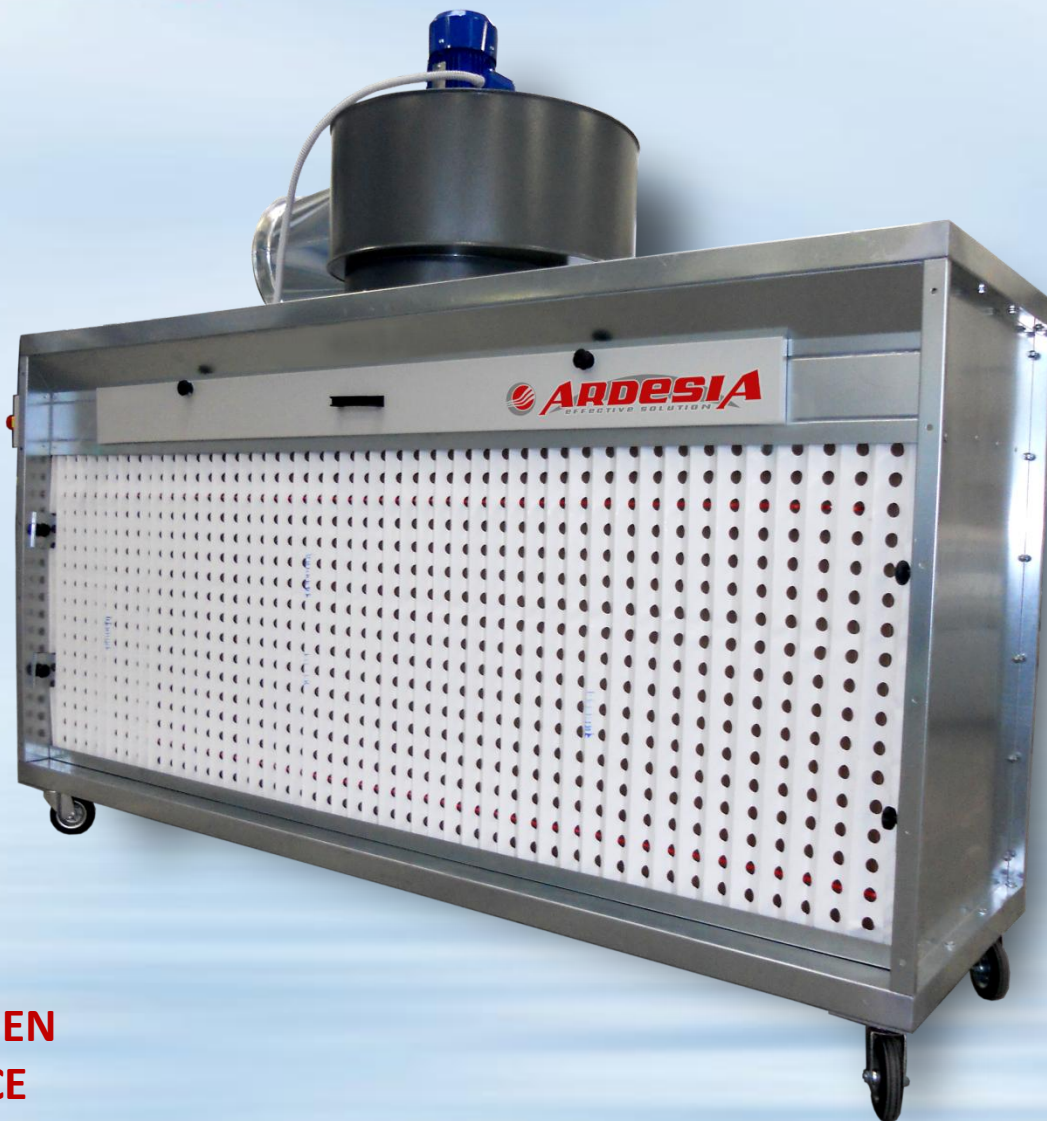

DRY PAINTING BOOTH

MODEL: **ROLLER**



**ACTIVE SOLUTIONS BETWEEN
INDUSTRY AND AMBIENCE**

ARDESIA SRL via Biagio di Santolino 96, 47892 – Aquaviva, Repubblica di San Marino
Tel: +378.0549805565 Fax: +39.05411811003 info@ardesiasrl.net www.ardesiasrl.net
The content of this brochure is for illustration and advertising. Ardesia Srl reserves the right to make any necessary changes to improve the products.

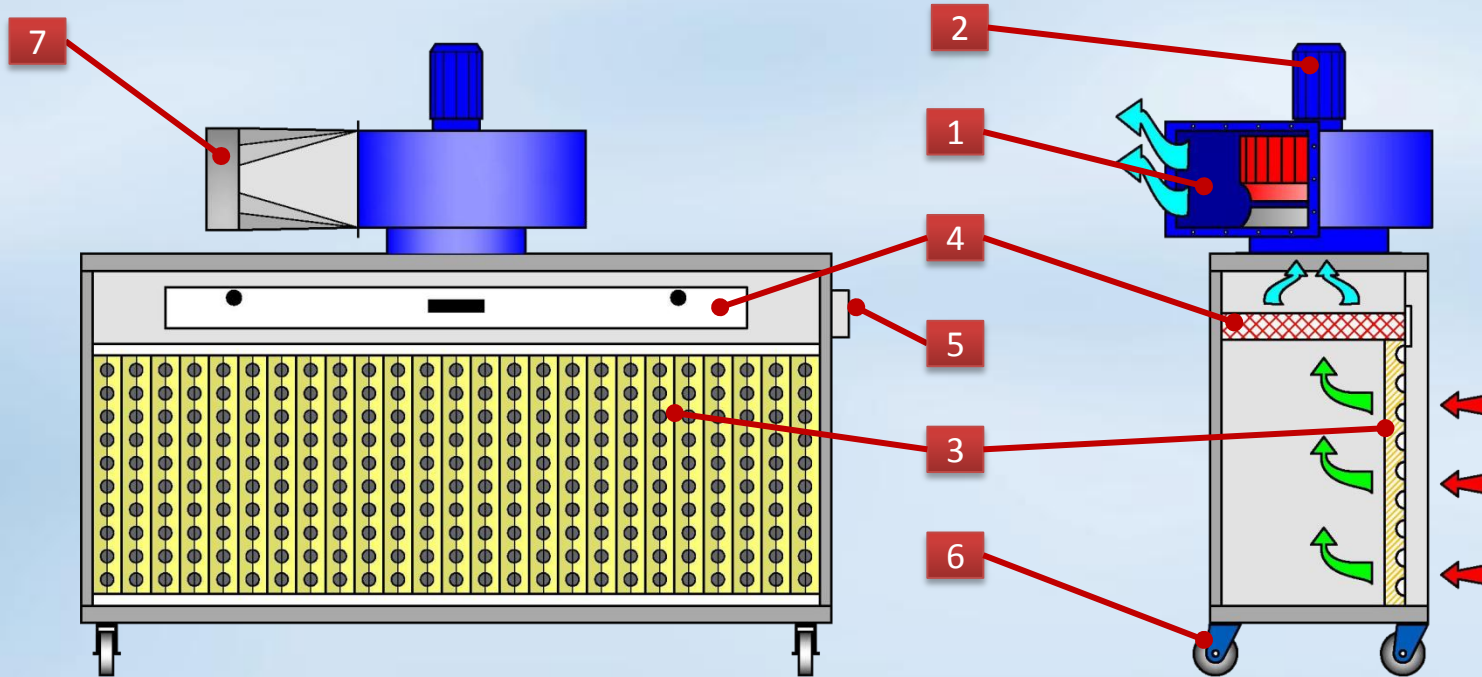

CERTIFICATION

**DESCRIPTION:**

This type of painting booth is suitable for suctioning and demolishing the pigments and fumes emitted from paint-spray made with synthetic solvents, organic and water. It is built with modular panels of galvanized press-folded sheet-iron. The main features of these booths are their small dimensions and the possibility of easy transfer. This booth utilizes a suctioning wall of cardboard inertial and a second filtration with "Paint-Stop" filter drawers.

EQUIPMENT:

1. Antispark centrifugal electrical fan
2. Energy-saving electric motor IE2
3. Frontal cardboard inertial filters
4. Metallic drawers with "Paint-Stop" filter
5. Wired electrical panel IP 55
6. Wheels
7. Change section

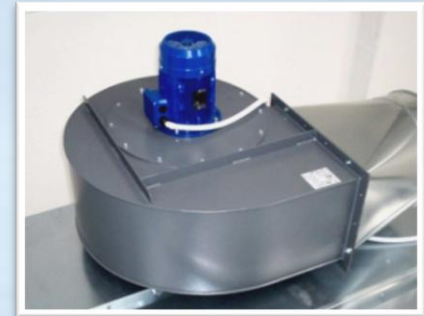
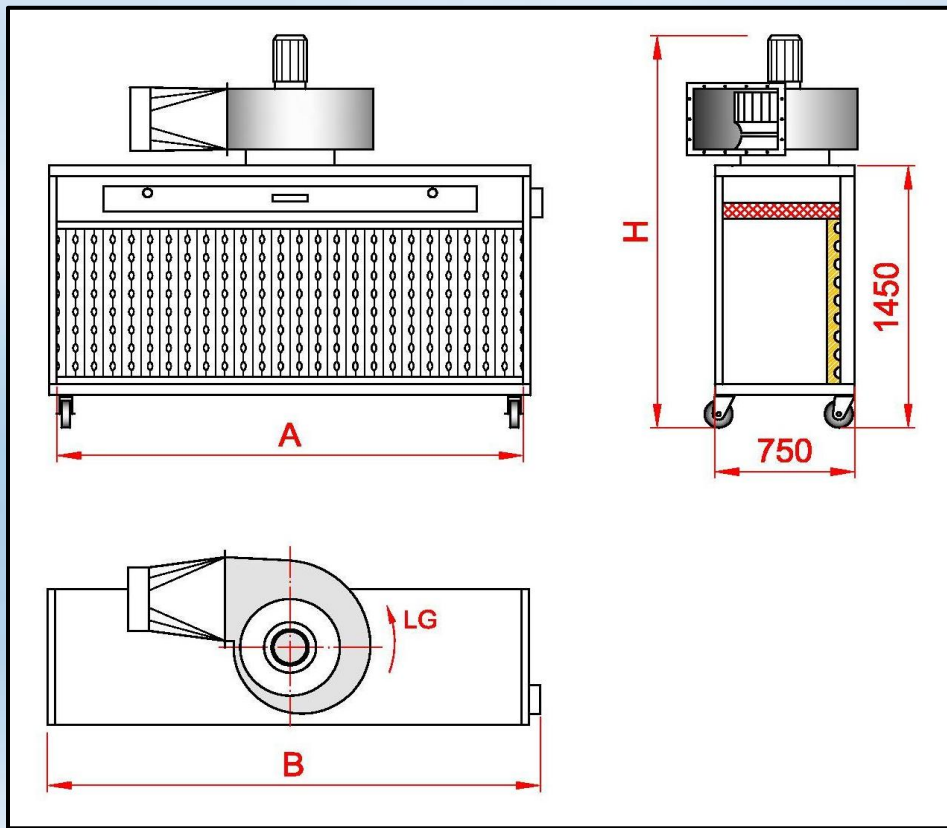

Model	A Usable width, mm	B Overall width, mm	H Overall height, mm	Diameter outbound tube, mm	Exhaust fan, power, kW	Nominal air flow m ³ / h
ROLLER - 1.5	1500	1600	1900	300	0,75	3000
ROLLER - 2	2000	2100	2100	300	1,1	5000
ROLLER - 2.5	2500	2600	2100	350	1,5	8000
ROLLER - 3	3000	3100	2200	350	2,2	11000

