

WAGNER

for **massive**
duties.



WAGNER PROTEC 2K
Mixing and dosing system

Robust and dependable.
Easy to use.
Rapid amortization.

www.wagner-group.com

Those who mix this way have a clear advantage

WAGNER PROTEC 2K – the new mixing unit for Protective Coating

- High saving potential for fast amortization
- Extremely robust, powerful and long-lasting
- Simplest operation and maintenance



ntage

WAGNER supplies machines, equipment, and systems for all areas of industrial surface coating. Our innovative products and solutions stand for quality, efficiency, and productivity.

Modern high-performance corrosion protection and marine coatings are formulated with high and ultra high solid content - most of them are 2-component based. These coatings require an accurate proportioning and mixing of the resin with the hardener to ensure the chemical reaction which enables the mixture to harden and reach the expected chemical and mechanical properties.

The new WAGNER PROTEC 2K was specially developed for this application. It takes over the precise dosing of the components as well as the elaborate and time-consuming mixing. You will be surprised how easy the system is to use. It operates almost as simple as a 1K piston pump!

The advantages are easy to see:

- You save time because you don't need to mix or stir any material in advance.
- You save material because you mix only as much as you need.
- You work without being concerned that the pot life will expire before completion of the coating.
- You save time and material because you do not flush the entire system in case of a longer interruption of work, only the parts that contain mixed material will be flushed (mixing block, material hose, spray gun).
- You avoid coating defects: The correct mixing ratio is determined by the system and guarantees the best possible coating quality.

Convincing! Simplest operation – high efficiency

The details of the **WAGNER PROTEC 2K** bring all the advantages of maximum performance to the point:



Precise mixing

Automatic and continuous dosing of the coating materials.



Dependable supply

Two large hoppers and the large intake valves at the pump ensure a constant and reliable material supply.



Air motor

Easy to handle, with soft-start function and full pressure steering for excellent reliability.

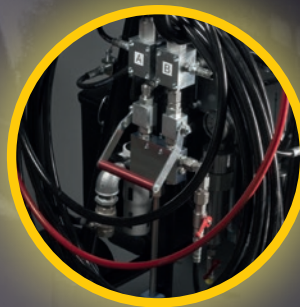

Large savings

Only the exact amount of material which is required is mixed. Only those parts of the appliance are flushed that are used for mixing (mixer, material hose, spray gun).

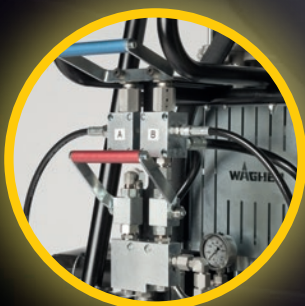

User-friendly

Clearly laid out and easy to use, similar to a normal 1K piston pump.



Always under control

The pressure gauge is easily visible. An automatic pressure relief ensures maximum safety.

ciency!

Extremely stable cart

Additionally protects pump and accessories.

New 10" air motor

Ensures sufficient pressure up to 500 bar.

Circulation valve

For the circulating operation of both components.

Pressure relief valve

Automatic circulation, if a tank is inadvertently empty.

Mixing block

With flushing connection. Removable when external mixer is required.

Air supply

With shut-off valve. For 1" air hose.

Material filter with return flow

Easy emptying and rinsing of the material filter.

Large solid rubber wheels

Excellent rolling characteristics for all terrain. No air leakage.

Flush pump Leopard 35-70

Optional, also as set for retrofitting.

Pressure gauge

For permanent pressure monitoring.

Robust feeding pumps

The fluid section can be easily exchanged for changing the mixing ratio.

Solid rubber tail wheel

With integrated brake.

Large DN 38 intake area

Large cross section for optimal intake. Easy to clean.



Fill with material and start

Simplicity is the key. Fill and start,
the **WAGNER PROTEC 2K** takes care of everything else.

The WAGNER PROTEC 2K is available in four variants with the preset mixing ratios 4:1, 3:1, 2:1 or 1:1. This makes it the ideal system for most commercially available coating materials. If a material change requires a different mixing ratio, the fluid section can be easily replaced. Of course, the WAGNER PROTEC 2K meets all ATEX requirements.

Typical materials are, for example:

- Highly filled zinc primers with epoxy base
- Polyurethane top coats
- Fast reacting tank coatings
- Fire-retardant paints

Typical applications

- Tanks
- Pipes
- Marine/shipbuilding
- Bridges
- Towers of wind energy systems
- Rail vehicles
- Water towers
- Wastewater treatment
- Maintenance of wells and sewer systems
- Overflow basins
- Coating of structural steel
- Refineries

Conventional 1K spray pack

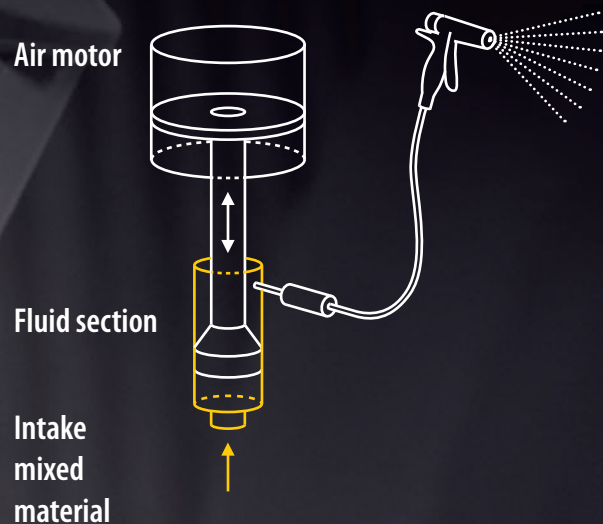

PROTEC 2K spray pack

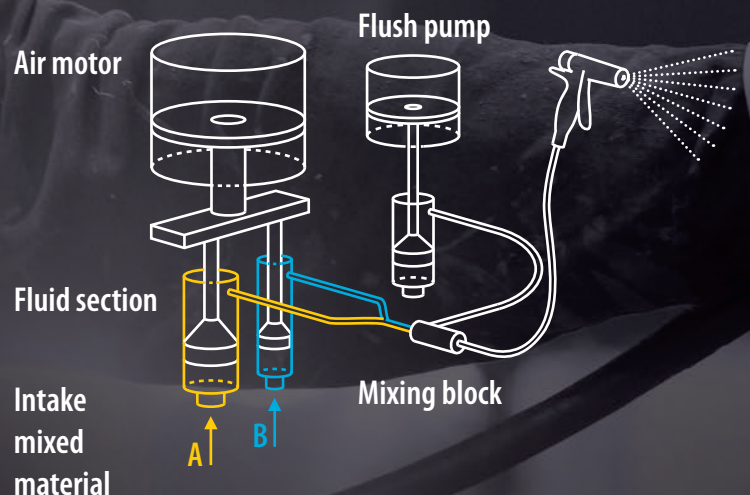

Operation of the PROTEC 2K:

When using a conventional piston pump, the two components must be precisely dosed and mixed prior to application.

With the PROTEC 2K, a separate fluid section works for each material component under the same air motor. The mixing ratio is determined by the selected fluid section.

Efficiency to be proud of

Save a lot of material and time – that pays off.

Reduce your material costs

The WAGNER PROTEC 2K only mixes the material you actually need. You no longer need to expensively dispose of excess material. Additionally you can purchase materials in larger packages and to save through volume discounts.

Lower your solvent consumption

Only those parts of the system are flushed which have come into contact with the mixed material – mixing block, material hose, and spray gun. This is particularly interesting in the event of a production stoppage. In comparison, you have to flush and clean a 1K system completely which costs significantly more time and solvent! Depending on the sensitivity of the hardener, you can let the system stand with un-mixed material inside overnight or several days.

Sensible workforce management

The dosing and mixing of the components takes place "just in time" and fully automated during the suction of the material components. This saves valuable labor time. The coating quality is significantly increased by the exact dosing and preparation of materials. Manual error rates are ruled out.

Low maintenance costs – high availability

In the fluid sections there is only unmixed material that can be rinsed out much easier than already-mixed components. This increases the maintenance intervals significantly. The WAGNER fluid sections can be dismantled with a few simple steps and are easy to maintain. The service sets available as accessories contain all the required components.

Savings potential

	Conventional 1K spray pack	PROTEC 2K spray pack
Dosing correct amount of catalyst	high demands on precision	automatic
Stirring and mixing	time-consuming	automatic
Pot life	Countdown of pot life once the hardener and resin are pre-mixed in the can	Right before the application, material is freshly mixed
Flushing and cleaning	complete flushing of the system	only the mixed material in the mixer and material hose need to be flushed
Pre-mixed coating waste	excess mixed material must be disposed of	no waste
Solvent consumption during flushing	10 - 15 liters depending on the size of the pump	2 - 3 liters, depending on the material hose, length and Ø
Pre-mixed coating waste during flushing	3 - 4 liters, depending on the size of the pump	1 - 2 liters, depending on the material hose, length and Ø

A worthwhile investment

Examples illustrate the high potential for savings with the **WAGNER PROTEC 2K**.

Cost and savings with the PROTEC 2K

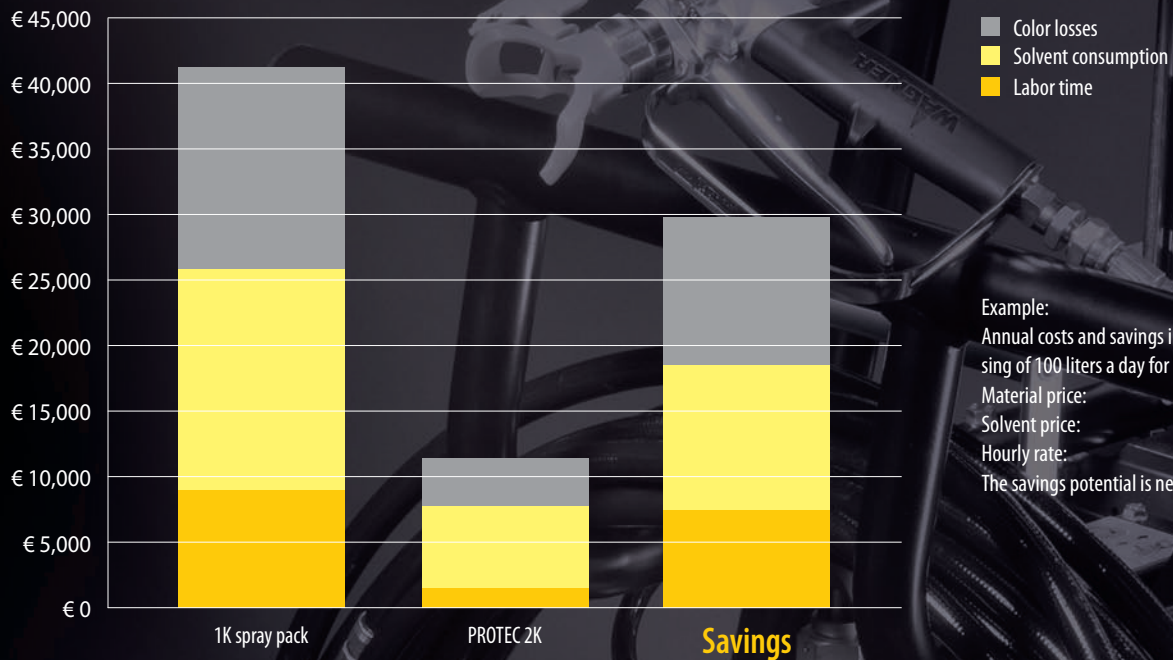

Example:
Annual costs and savings in the processing of 100 liters a day for 150 days;
Material price: € 9.00/liter.
Solvent price: € 4.00/liter;
Hourly rate: € 40/h.
The savings potential is nearly € 30,000

A direct comparison with a 200 cm³ piston pump demonstrates the high potential for savings. The following conditions are the basis for this example:

Daily processing volume: 100 liters 2K material at € 9.00/l
Solvent price € 4.00/l

Hourly rate of your employees € 40.00/h

incl. incidental costs: One work break daily, longer than the pot life, flushing necessary.

One cleaning of the piston pump daily. For the WAGNER PROTEC 2K every two days, because the unmixed material can remain in the pump.

Working period: 150 days / year

Material loss due to excess prepared material: 5% of the total amount

The purchase price of WAGNER PROTEC 2K pays for itself in about nine months. The greatest savings occur in material costs. The daily cleaning of the 1K piston pump and the material preparation and quantity with conventional processing provide for high costs. Even if the daily work break is omitted, the savings are still significantly higher compared to the purchase price of a WAGNER PROTEC 2K system.

Cost expenditures	1K Spray pack	PROTEC 2K	Savings
Working time	€ 9,000.00	€ 1,550.00	€ 7,450.00
Rinsing agent consumption	€ 17,160.00	€ 6,120.00	€ 11,040.00
Mixed coating waste	€ 15,390.00	€ 3,982.50	€ 11,407.50
Total savings / year			€ 29,897.50

For a perfect match

Excellent accessories for an extraordinary performance and excellent coating results.



Flush pump set

Piston pump Leopard including all attachments.



Heater set

Optionally for use with A or B component.



Heated tanks

Extremely high viscosity material can be made workable by using the heated tanks.



PROTEC GM 1

The ideal airless manual gun for Protective Coating. Extremely easy to handle, robust, with excellent atomization properties.



AVAILABLE SOON: MOUNTING KIT EXTERNAL MIXER

The mixing block can be dismantled and used as an external mixer. Ideal for short pot life and very expensive materials.

Flexibility for other mixing ratios

Just briefly change the mix – variable, for greater flexibility in your requirements.

The WAGNER PROTEC 2K is available in four different mixing ratios. The mixture required is defined by the proportions of the two fluid sections to each other.

If these are to be changed, the fluid sections can be exchanged accordingly. The exchange takes about 20 minutes only.

Fluid sections for different mixing ratios:	Fluid section 150 cm ³	Fluid section 110 cm ³	Fluid section 110 cm ³	Fluid section 75 cm ³	Fluid section 50 cm ³	Fluid section 38 cm ³
Mixing ratio 4:1	A					B
Mixing ratio 3:1	A				B	
Mixing ratio 2:1	A			B		
Mixing ratio 1:1		A	B			



Our system performs

Technical data at a glance.

Technical data	PROTEC 2K 75-150/38	PROTEC 2K 70-150/50	PROTEC 2K 64-150/75	PROTEC 2K 65-110/110
Mixing ratio	4:1	3:1	2:1	1:1
Pressure ratio	75:1	70:1	64:1	65:1
Operating pressure max.	500 bar	465 bar	415 bar	420 bar
Fluid section A double stroke volume	150 cm ³	150 cm ³	150 cm ³	110 cm ³
Fluid section B double stroke volume	38 cm ³	50 cm ³	75 cm ³	110 cm ³
Flow rate per double stroke	188 cm ³	200 cm ³	225 cm ³	220 cm ³
Flow per 30 double strokes	5.64 l	6.0 l	6.75 l	6.6 l
Stroke rate max.	30 DS/min	30 DS/min	30 DS/min	30 DS/min
Material inlet (tank)	27 l	27 l	27 l	27 l
Material outlet (BSP)	A - G3/8"	A - G3/8"	A - G3/8"	A - G3/8"
Air supply pressure	1.5 - 6.5 bar	1.5 - 6.5 bar	1.5 - 6.5 bar	1.5 - 6.5 bar
Noise level at 6 bar air pressure	80 dB(A)	80 dB(A)	80 dB(A)	80 dB(A)
Material temperature	5 - 80° C	5 - 80° C	5 - 80° C	5 - 80° C
Ambient temperature	5 - 60° C	5 - 60° C	5 - 60° C	5 - 60° C
Material pH value	3.5 - 9 pH	3.5 - 9 pH	3.5 - 9 pH	3.5 - 9 pH
Material pressure pump inlet max.	20 bar	20 bar	20 bar	20 bar
Weight	190 kg	190 kg	190 kg	190 kg
ATEX designation	II 2G cIIB T3 / T4 Gb X	II 2G cIIB T3 / T4 Gb X	II 2G cIIB T3 / T4 Gb X	II 2G cIIB T3 / T4 Gb X
Dimensions (W x L x H)	830 x 1200 x 1710 mm	830 x 1200 x 1710 mm	830 x 1200 x 1710 mm	830 x 1200 x 1710 mm



All systems are naturally ATEX-compliant!

The WAGNER PROTEC product family

Everything you need for heavy-duty corrosion protection.



WAGNER PROTEC spray packs

The WAGNER PROTEC piston pumps reliably ensure sufficient pressure at the gun for a perfect paint job.



WAGNER PROTEC GM 1

Airless manual gun



WAGNER PROTEC TwinControl

Electronic mixing systems for Protective Coating.



WAGNER PROTECTIP

Airless reversible tips up to 530 bar



WAGNER PROTEC accessories

Especially for high solid material, WAGNER provides the correctly coordinated accessories e.g. suction hoses, tanks, heaters, material hoses and nozzles.



J. Wagner GmbH
Industrial Solutions
D-88677 Markdorf
Phone +49 (0) 7544 505-0
Fax +49 (0) 7544 505-1200

J. Wagner AG
Industrial Solutions
CH-9450 Altstätten/SG
Phone +41 (0) 71 7572211
Fax +41 (0) 71 7572323



www.wagner-group.com